

108-5118

Rev. J1

Product Specification

(製品規格)

AMP EI Series Connector

(AMP EI シリーズコネクタ)

Following first 10 pages are English version and last 9 pages are Japanese version. This top sheet is not part of the specification but explains both of English and Japanese versions are available.

このトップシートに続く最初の 10 ページは英語版で、その後の 9 ページは日本語版です。このトップシートは、規格には含まれませんが、英語、日本語両方があることを説明しています。

Product Specification

108-5118

AMP "EI" Series, Connector

NUMBER  
108-5118

CUSTOMER  
RELEASE

AMP SECURITY  
CLASSIFICATION

1. General Descriptions:

This connector has been designed in single line contact disposition in 2.5mm center line spacing. The connectors of vertical and horizontal types for wire-to-board termination, and panel mounting and free hanging types for wire-to-wire termination, are available.

2. Scope:

The products of "EI" series connectors, excepting mass termination type are governed under this specification.

3. Material and Finish:

3.1 Contact, Crimp Type:

(1) Tin-Plated Products:

Materials: Brass and Phosphor Bronze  
Finish: Pretinned, 0.8 μm minimum thick

(2) Gold-Plated Products:

Materials: Phosphor Bronze  
Finish: 0.38 μm minimum thick gold-plated for contact area only, over 1.0-2.0 μm minimum thick nickel underplate

3.2 Post:

(1) Tin-Plated Products: (Vertical and Horizontal Types)

Materials: Brass Wire  
Finish: 0.8 μm minimum thick tin-plated over 0.5 μm minimum thick copper underplate

(2) Gold-Plated Products: (Vertical Type)

Material: Brass Wire  
Finish: 0.38 μm minimum thick gold plated over 1.0-2.0 μm thick nickel underplate

3.3 Housing:

(1) Material: 6/6 NYLON

(2) Flame Retardancy:  
UL94V-0

PRINT LIST	J1	Corrected FJ00-0613-99	11/11/87	ZAPR 89	DR			AMP (Japan), Ltd. TOKYO, JAPAN		
	J	REVISED RFA-1695	JF SIL 7/88	CHK	Y. Nakamura					
	H	Revised RFA-1534	F 3/6 1/188	CHK	Tanigawa 3/11/87		LOC	NO	REV	
	G <sub>1</sub>	Para.4.2.12 Revised	11/11/87	CHK	J. Rowe 3/12/87		J	A	108-5118	J1
	G <sub>2</sub>	Revised RFA-1127	11/11/87	CHK	J. Rowe 3/12/87					
LTR	REVISION RECORD	DR	CHK	DATE	SHEET 1 OF 10		NAME Product Specification AMP "EI" Series, Connector			

4. Performance:

4.1 Rating:

- (1) Voltage: 250V AC and 350V DC
- (2) Current: 2A (Refer to Fig. 1.)
- (3) Temperature: Refer to Fig. 1.

4.2 Performance Requirements:

When tested in accordance with the applicable test method, all the products shall show performance capability to be acceptable to the following requirements.

Para-graph	Test Items	Specified Requirements		Test Method Para. No.	
4.2.1	Termination Resistance	Low level termination resistance shall be 10 mΩ max.		6.1	
4.2.2	Insulation Resistance	Insulation Resistance shall be 500MΩ min. when measured at 500V DC.		6.2	
4.2.3	Dielectric Strength	Connector shall show no abnormalities after applying test potential of 750V AC for 1 minute.		6.3	
4.2.4	Temperature Rising	Temperature rising of connector shall be 30 deg. max. (Refer to Fig. 1.)		6.4	
4.2.5	Contact Retention Force	Brass Contact	Phosphor Bronze Contact	6.5	
		19.6N (2Kgf) min. (4.41 lbs.) per position	24.5N (2.5Kgf) min. (5.51 lbs.) per position		
4.2.6	Vibration (Low Frequency)	No electrical discontinuity greater than 1 microsecond shall not occur during the test.		6.6	
		Termination Resistance; (Low Level)	Tin-Plated Products		20 mΩ max.
			Gold-Plated Products:		18 mΩ max.

(Table 1)  
(To be continued)

SHEET				AMP (Japan), Ltd. TOKYO, JAPAN	
2	OF 10	LOC	A	NO	108-5118
		REV.		J1	
NAME AMP "EI" Series Connector					

(Continued)

108-5118

NUMBER

AMP SECURITY CLASSIFICATION  
Customer Release

Para-graph	Test Items	Specified Requirements				Test Methods Para. No.
4.2.7	Humidity: (Steady State)	No abnormalities such as cracks, blister and other defects that are detrimental to connector functions, shall be present.				6.7
		Termination Resistance: (Low Level)	Tin-Plated Products:	20 mΩ max.		
			Gold-Plated Products:	18 mΩ max.		
4.2.8	Salt Spray:	No abnormalities such as cracks, blister and other defects that are detrimental to connector functions, shall be present.				6.8
		Termination Resistance: (Low Level)	Tin-Plated Products:	20 mΩ max.		
			Gold-Plated Products:	18 mΩ max.		
4.2.9	Solderability (Applicable to post header Only)	More than 95% of the tested area shall appear with sufficient coverage of wet solder.				6.9
4.2.10	Soldering Heat Resistivity: (Applicable to post header only)	Connector shall be free from the deformation and defects that are detrimental to connector functions.				6.10
4.2.11	Crimp Tensile Strength:	Wire	Size	Tensile Strength		6.11
		mm <sup>2</sup>	(AWG)	N (Kgf)	(lbs.)	
		0.52	(#20)	68.6N (7Kgf)	(15.43)	
		0.3	(#22)	49.0N (5Kgf)	(11.02)	
		0.2	(#24)	29.4N (3Kgf)	( 6.61)	
		0.13	(#26)	19.6N (2Kgf)	( 4.41)	
		0.08	(#28)	12.7N (1.3Kgf)	( 2.87)	
		0.05	(#30)	7.8N (0.8Kgf)	( 1.76)	

(To be continued)

SHEET				AMP (Japan), Ltd. TOKYO, JAPAN	
3 OF 10		LOC	A	NO	108-5118
		J			REV. J1
NAME AMP "EI" Series Connector					

4.2 Performance Requirements:

108-5118

NUMBER

AMP SECURITY - Customer Release CLASSIFICATION

Para-graph	Test Item	Specified Requirements			Test Method Para-graph Number	
4.2.12	Post Retention Force	Retention force shall be 19.6N (2Kgf) (4.41 lbs.) min.			6.12	
4.2.13	Contact Insertion and Extraction Force	Contact insertion/extraction force shall be conforming to the value specified below.			6.13	
			Insertion	Extraction		
		Initial	0.6 kg (Max.)	0.1 kg (Min.)		
	10th. Cycle	0.6 kg (Max.)	0.08kg (Min.)			
4.2.14	Connector Insertion and Extraction Force	No. of Positions	Measured at	Insertion Force (Max.) kg (lbs.)	Extraction Force (Min.) kg (lbs.)	6.14
		12	Initial	73.5N (16.5)	19.6N(2.0Kgf)(4.4)	
			10 th.	(7.5Kgf) (16.5)	14.7N(1.5Kgf)(3.3)	
		10	Initial	(15.4)	19.6N(2.0Kgf)(4.4)	
			10 th.	68.6N (15.4)	14.7N(1.5Kgf)(3.3)	
		9	Initial	(7.0Kgf) (15.4)	19.6N(2.0Kgf)(4.4)	
			10 th.	(15.4)	14.7N(1.5Kgf)(3.3)	
		8	Initial	63.7N (14.3)	14.7N(1.5Kgf)(3.3)	
			10 th.	(6.5Kgf) (14.3)	9.8N(1.0Kgf)(2.2)	
		7	Initial	53.9N (12.1)	14.7N(1.5Kgf)(3.3)	
			10 th.	(5.5Kgf) (14.3)	9.8N(1.0Kgf)(2.2)	
		6	Initial	49.0N (11.0)	14.7N(1.5Kgf)(3.3)	
			10 th.	(5.0Kgf) (11.0)	9.8N(1.0Kgf)(2.2)	
5	Initial	39.2N (8.8)	14.7N(1.5Kgf)(3.3)			
	10 th.	(4.0Kgf) (8.8)	9.8N(1.0Kgf)(2.2)			
4	Initial	29.4N (6.6)	9.8N(1.0Kgf)(2.2)			
	10 th.	(3.0Kgf) (6.6)	7.8N(0.8Kgf)(1.8)			
3	Initial	24.5N (5.5)	7.8N(0.8Kgf)(1.8)			
	10 th.	(2.5Kgf) (5.5)	4.9N(0.5Kgf)(1.1)			
2	Initial	19.6N (4.4)	7.8N(0.8Kgf)(1.8)			
	10 th.	(2.0Kgf) (4.4)	4.9N(0.5Kgf)(1.1)			
4.2.15	Panel Insertion and Retention Force (Applicable to panel mount type connector)	Panel Insertion Force	7 & 8-Pos.	78.4N (8Kgf) max.	6.15	
			2~6 Pos.	49.0N (5Kgf) max.		
		Panel Retention Force	7 & 8-Pos.	9.8N (1.0Kgf) min.		
			2~6 Pos.	19.6N (2.0Kgf) min.		

Table 1 (End)

5. Quality Assurance Provisions:

5.1 Test Specimens:

Test specimens shall be prepared in accordance with the methods and procedure specified by appropriate AMP specification and instruction sheet, by using applicable application tooling.

SHEET		<b>AMP</b> AMP (Japan), Ltd. TOKYO, JAPAN		
4	OF 10			
LOG	J	A	NO	108-5118
REV	J1			
NAME AMP "EI" Series Connector				

5.2 Test Conditions:

All the tests shall be conducted under any combination of the following test conditions.

Temperature: 15 - 35°C  
 Relative Humidity: 45 - 75%  
 Atmospheric Pressure:  $8.7 \times 10^4 \sim 1.07 \times 10^5$  MPa  
 (650~800 mmHg)

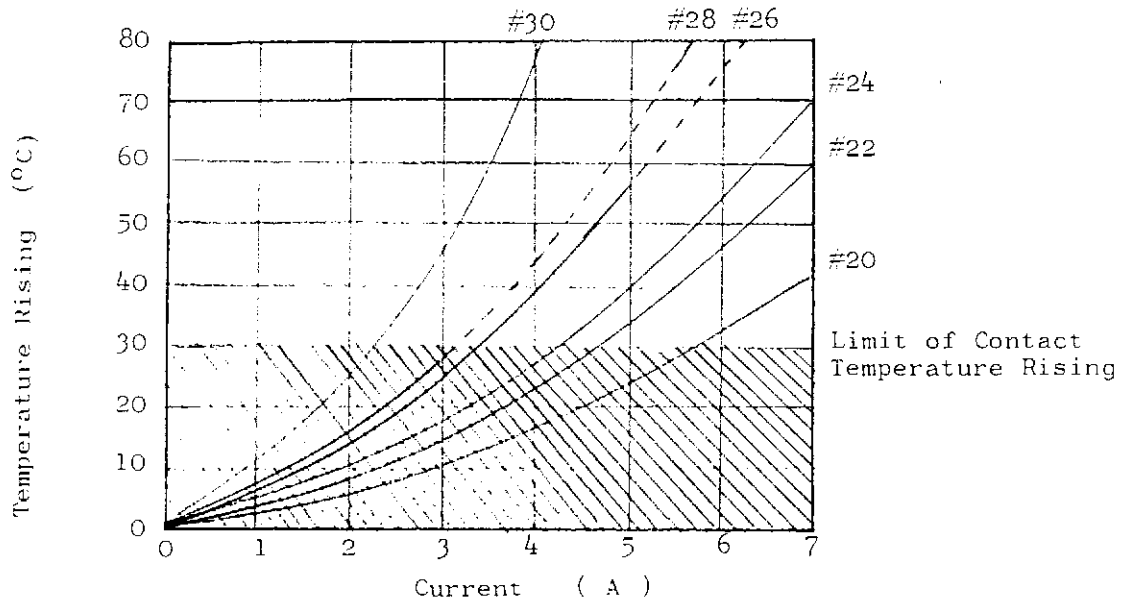

Fig. 1

The maximum current that can be carried in any given connector is limited by maximum operating temperature of housing material used and influenced by the wire size, connector size (number of cavities operating) and the ambient temperature in which the connector is used. The maximum intensity of current can be calculated by the following formula, taking consideration of temperature rating specified in the range of -20°C through +95°C (-13.0°F through +203°F) and maximum allowable temperature for tin-plated connector.

$$\text{Maximum Operating Temperature} = \text{Temperature Rise} + \text{Ambient Temperature}$$

The rate of temperature rising must be held within the limit obtained from maximum allowable current loaded on individual operating wire and total current shall be determined by the curves shown in Fig. 1. In any case, total amount of temperature rising shall be held within 30 degrees over the ambient temperature.

Note: The dotted line section indicates estimated rate of temperature rising.

SHEET		<b>AMP</b>		AMP (Japan), Ltd. TOKYO, JAPAN	
5 OF 10		LOC	NO	REV	
		J	A	108-5118	
NAME					
AMP "EI" Series Connector					

6. Test Methods:

6.1 Termination Resistance (Low Level):

Low level termination resistance is obtained by measuring millivolt drop of the test circuit as shown in Fig. 2, by applying test current of 50 mA at open circuit voltage of 50mV flowing through the circuit. From the measured value, low level resistance is calculated after deducting resistance of crimped wire of 75mm in length.

6.2 Insulation Resistance:

Insulation resistance is obtained by applying test potential of 500V DC across the adjacent contacts in the connector housing after connector is mated without having post header mounted on printed circuit board.

6.3 Dielectric Strength:

Dielectric strength is measured by applying test potential of 750V AC across the adjacent contacts in the connector housing after connector is mated without having post header mounted on printed circuit board.

6.4 Temperature Rising:

After having contacts series wired, measure temperature rising of contacts by probing on wire crimp by using thermocouple.

6.5 Contact Retention Force:

Contact loaded housing must be fastened on the head of tensile testing machine, and apply an axial pull off load to contact lead by operating the head to travel with the speed at a rate of 100mm a minute. Contact retention force is determined when receptacle contact is dislodged from housing cavity.

6.6 Vibration:

Contact loaded and mated pair of connectors must be mounted on printed circuit board or mounting panel with all the contacts series wired, and fastened on the vibration table. The said connectors are vibrated with maximum amplitude of 1.5mm both sides in the sweeping frequencies to reciprocate between 10 and 55 Hz., changing at a rate of one cycle a minute. During the vibration, the circuit must be monitored by applying test current of 0.1A for occurrence of electrical discontinuity resulted from the vibration. Vibration must be applied to the sample connector in three axial planes for totally 6 hours, each plane vibrated for 2 hours.

6.7 Humidity:

Humidity testing shall be performed by exposing the contact-loaded and mated pair of connectors under the atmosphere of 90-95% R.H. at 40°C for 96 hours in the test chamber, and after the test duration, recondition in the room temperature for 1 hour before undergoing the subsequent measurements.

6.8 Salt Spray:

Contact-loaded and mated pair of connectors shall be exposed under the 5% salt solution spray for 48 hours at 35 C. After completion of test duration, the sample connectors shall be taken out from the test chamber and reconditioned in the room temperature for 1 hour, and tested for low level termination resistance.

SHEET		<b>AMP</b> AMP (Japan), Ltd. TOKYO, JAPAN		
6 OF 10	LCC			
	J	A	108-5118	J1
NAME AMP"EI" Series Connector				

- 6.9 Solderability: (Applicable to Post Header, Wire-to-Board Only):  
Dip contact ends of post header in flux (ALPHA 100 GX-5 or GX 7 is recommended.) for 5 - 10 seconds, then, immerse in soldering tub that is filled with 60% tin, 40% lead solder heated at  $230 \pm 5^{\circ}\text{C}$ , for  $10 \pm 0.5$  seconds.
- 6.10 Soldering Heat Resistivity ( Applicable to Post Header, Wire-to-Board Type Only):  
With post header inserted into the mounting holes, printed circuit board shall be processed for soldering for for  $10 \pm 0.5$  seconds in the soldering tub where the temperature is controlled at  $250 \pm 5^{\circ}\text{C}$ .  
(Manual Soldering)  
In case of manual soldering, test the sample post header assembled on PCB, by applying soldering iron, controlled at  $350 \pm 10^{\circ}\text{C}$  for 1 to 2 seconds. In this testing, soldering spot of the post shall remain free from the pressure by the applied soldering iron.
- 6.11 Crimp Tensile Strength:  
Fasten a wire-crimped contact lead onto the head of tensile testing machine and apply an axial pull off load to the wire by operating the head to travel with the speed at a rate of 100mm a minute without insulation support crimp set in effect. Crimp tensile strength is determined when the wire is broken or is pulled off from the wire crimp.
- 6.12 Post Retention Force (Applicable to Post Header, Wire-to-Board Type Only):  
Place post inserted header assembly over the test fixture in the manner as shown in Fig. 3, and apply an axial push down force on top of post contact. Post retention force is determined when the post is dislodged from the inserted position. Measurement shall be done by using a force gage.
- 6.13 Contact Insertion/Extraction Force:  
Fasten a receptacle contact on the head of tensile testing machine, and apply axial loads to the receptacle contact to mate with and unmate from the gage, specified in Fig. 4, by operating the head to travel with the speed at a rate of 100mm a minute.
- 6.14 Connector Mating/Unmating Force:  
Fasten receptacle contacts loaded housing on tensile testing machine in the manner that they are aligned to mate with and unmate from the gage as the head is operated to travel with the speed at a rate of 100mm a minute.
- 6.15 Panel Insertion and Retention Force (Applicable to Post Header, Wire-to-Board Type Only):  
Fasten cap housing onto the head of tensile testing machine, and test the force required to insert the housing into the mounting hole that is made through the mounting panel, and the force required to pull-off the housing from the panel, by operating the head to travel with the speed at a rate of 100mm a minute.

SHEET		<b>AMP</b>		AMP (Japan), Ltd. TOKYO, JAPAN	
7 OF 10		LOC J	A	NO 108-5118	REV. J1
NAME Product Specification AMP "EI" Series, Connector					



7. Test Sequence:

The following sample groups shall be prepared, and employed for the tests in the sequence specified in Table 2 below.

Test Method Paragraph	Test Item	Sample Group											
		1	2	3	4	5	6	7	8	9	10	11	
6.1	Termination Resistance (Low Level)			1,3	1,3	1,3							
6.2	Insulation Resistance	1											
6.3	Dielectric Strength	2											
6.4	Temperature Rising		1										
6.5	Contact Retention Force	3											
6.6	Vibration (Low Frequency)			2									
6.7	Humidity				2								
6.8	Salt Spray					2							
6.9	Solderability						1						
6.10	Soldering Heat Resistibility							1					
6.11	Crimp Tensile Strength								1				
6.12	Post Retention Force									1			
6.13	Contact Insertion/Extraction Force										1		
6.14	Connector Mating/Unmating Force											1	
6.15	Panel Insertion and Retention Force												1

Table 2

SHEET		<b>AMP</b> AMP (Japan), Ltd. TOKYO, JAPAN			
8 OF 10	LCC J	A	NO 108-5118	REV J1	
NAME AMP "E1" Series Connector					

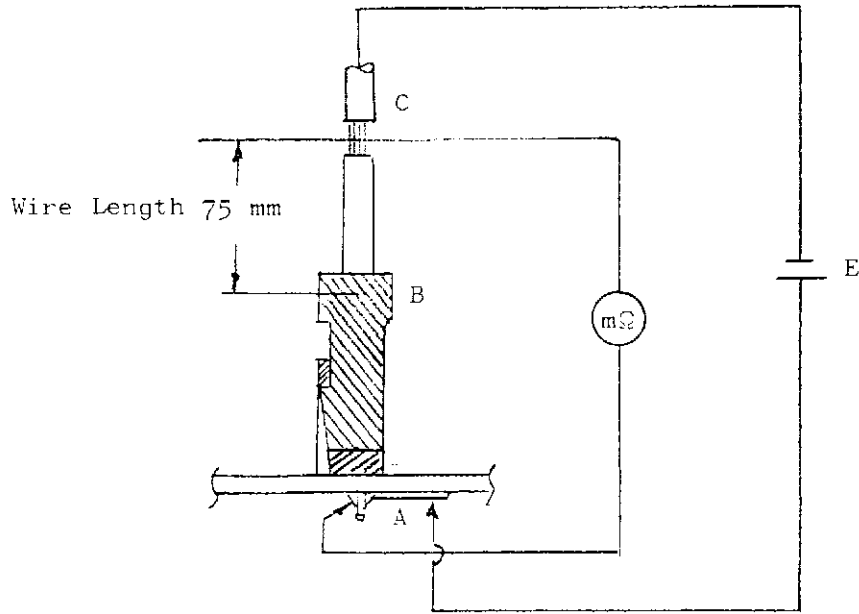

Termination Resistance "R" =  $A B = A C - B C$  ( $m\Omega$ )

Fig. 2a Wire-to-Board Type Termination Resistance Measuring Method

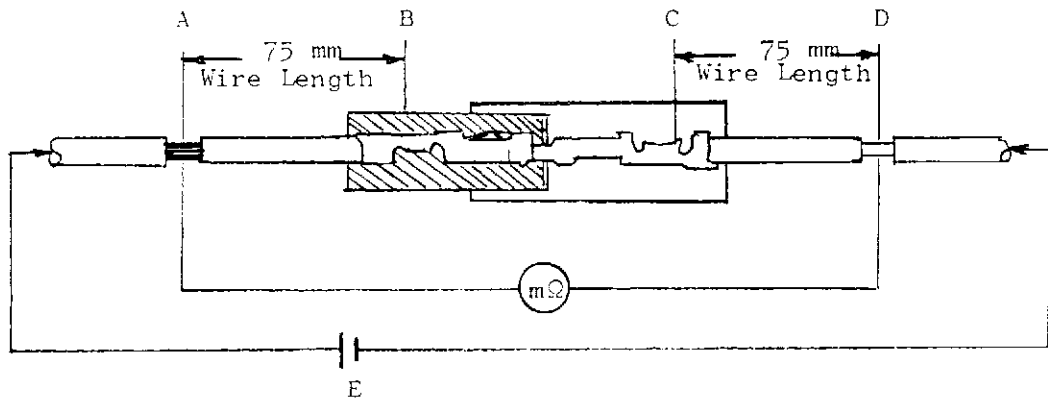

Termination Resistance "R" =  $A D - (A B + C D)$  ( $m\Omega$ )

Fig. 2b Wire-to-Wire Type Termination Resistance Measuring Method (Low Level)

SHEET		<b>AMP</b>		AMP (Japan), Ltd. TOKYO, JAPAN	
9 OF 10	LOC J	A	NO 108-5118	REV J1	
NAME					
AMP "EI" Series Connector					

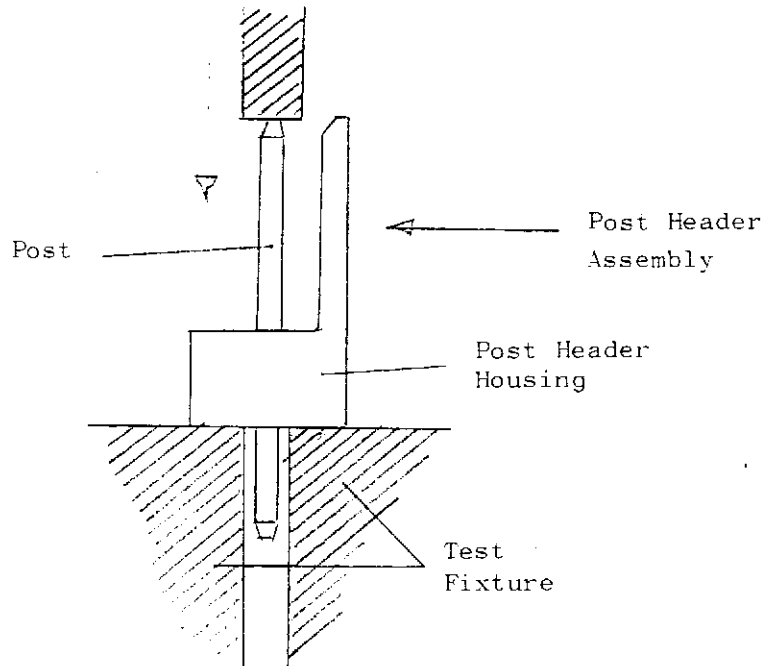

Fig. 3 Post Retention Force Measuring Method

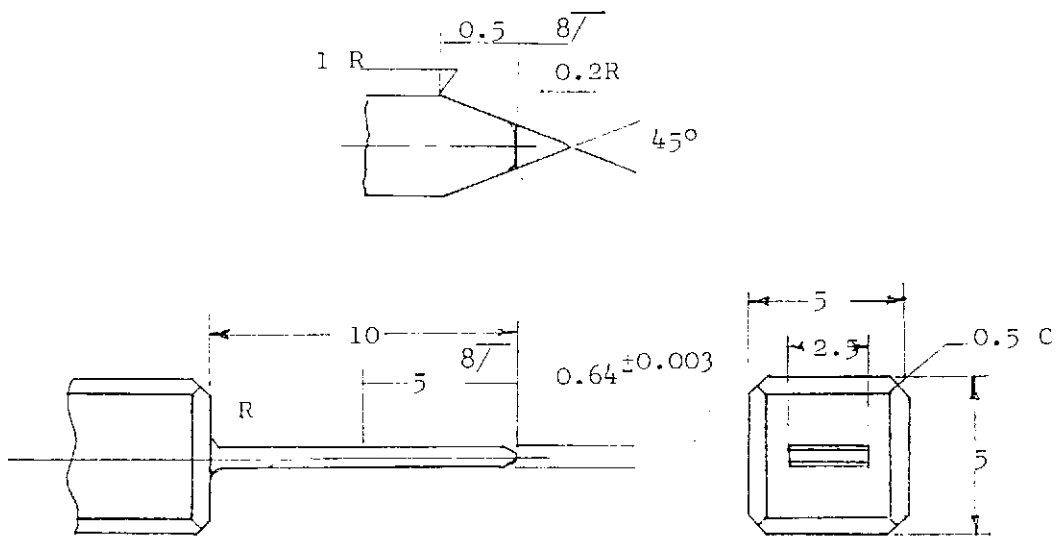

Fig. 4 Contact Insertion/Extraction Force Measuring Method

SHEET		<b>AMP</b> AMP (Japan), Ltd. TOKYO, JAPAN		
10	OF 10	LOC	NO	REV
		J	A	J1
NAME				
AMP "EI" Series, Connector				

# 社内標準



管理基準： 一般顧客用

(技術標準)

日本エー・エム・ピー株式会社

## 製品規格

108-5118

AMP E.I. シリーズ・コネクタ

### 1. 概要

本コネクタは一列の配列で極間は 2.5mm ピッチで構成されている。タイプは電線対基板の垂直型と水平型及び電線対電線のパネル取付型とフリーハンギング型がある。

### 2. 適用範囲

本規格は、マスターミネーションタイプを除く E.I. シリーズ・コネクタの全ての製品について適用する。

### 3. 材料及び表面処理

#### 3.1 コンタクト圧着タイプ

##### (1) 錫めっき製品

材質： 黄銅及び燐青銅

表面処理： 錫めっき済 0.8μm 以上

##### (2) 金めっき製品

材質： 燐青銅

表面処理： ニッケル下地めっき 1-2μm の上に接触部のみ金めっき 0.38μm 以上

#### 3.2 ポスト

##### (1) 錫めっき製品 (垂直タイプ及び水平タイプ)

材質： 黄銅線

表面処理： 銅下地めっき 0.5μm 以上の上に錫めっき 0.8μm 以上

##### (2) 金めっき製品 (垂直タイプ)

材質： 黄銅線

表面処理： ニッケル下地めっき 1-2μm の上に金めっき 0.38μm 以上

#### 3.3 ハウジング

(1) 材質： 66 ナイロン

(2) 難燃性： UL 94V-0

作成：

分類：

製品規格

谷川

J1 Corrected FJ00-0613-99 *K Yamada 2 APR 88*

検閲：

コード：

改訂

J 改訂 RFA 1695 *S. S. 1/10/80*

108-5118

J1

H 改訂 RFA-1534 *S. S. 1/10/80*

承認：

名称：

G 改訂 RFA-1127 *S. S. 3/20/87*  
改訂 改訂記録 作成 検閲 承認 年月日

AMP E.I. シリーズ・コネクタ

配布

昭和 52 年 8 月 1 日 制定 9 頁中 1 頁

## 4. 性能

## 4.1 定格

- (1) 電 圧 : AC 250V 及び DC 350V  
 (2) 電 流 : 2A (図1参照)  
 (3) 周囲温度 : 区1参照

## 4.2 一般性能

表1に示す一般性能に全て合格しなければならない。

表 1

項 番	試 験 項 目	規 格 値		試験方法 項 番
4.2.1	ローレベル抵抗	10 mΩ 以下		6.1
4.2.2	絶縁抵抗	500 MΩ 以上 (DC 500V において)		6.2
4.2.3	耐電圧	AC 750V, 1分間で異常なきこと。		6.3
4.2.4	温度上昇	30 °C 以下 (注・図1参照)		6.4
4.2.5	コンタクト保持力	黄銅コンタクト	りん青銅コンタクト	6.5
		19.6N (2Kgf) 以上 / 1極	24.5N (2.5Kgf) 以上 / 1極	
4.2.6	低周波振動	振動中1μ秒を超える不連続導通を生じないこと。 ローレベル抵抗: 錫めっき製品 20 mΩ 以下 金めっき製品 18 mΩ 以下		6.6
4.2.7	耐湿性 (定常状態)	割れ, フクレ, その他機能を損う欠陥のないこと。 ローレベル抵抗: 錫めっき製品 20 mΩ 以下 金めっき製品 18 mΩ 以下		6.7
4.2.8	塩水噴霧	割れ, フクレ, その他機能を損う欠陥のないこと。 ローレベル抵抗: 錫めっき製品 50 mΩ 以下 金めっき製品 18 mΩ 以下		6.8
4.2.9	はんだ付性 (ポストヘッダーのみに適用)	半田ヌレは 95% 以上		6.9
4.2.10	はんだ耐熱性 (ポストヘッダーのみに適用)	機能を損う変形, 欠陥のないこと。		6.10
4.2.11	圧着部引張強度	AWG # 20 (0.52 mm <sup>2</sup> )	68.6N (7Kgf) 以上	6.11
		AWG # 22 (0.3 mm <sup>2</sup> )	49.0N (5Kgf) 以上	
		AWG # 24 (0.2 mm <sup>2</sup> )	29.4N (3Kgf) 以上	
		AWG # 26 (0.13 mm <sup>2</sup> )	19.6N (2Kgf) 以上	
		AWG # 28 (0.08 mm <sup>2</sup> )	12.7N (1.3Kgf) 以上	
		AWG # 30 (0.05 mm <sup>2</sup> )	7.8N (0.8Kgf) 以上	
4.2.12	ポスト保持力 (ポストヘッダーのみに適用)	19.6N (2Kgf) 以上		6.12

表 1

項番	試験項目	規格値		試験方法 項番					
4. 2. 13	コネクタ単体挿抜力	初回	挿入力 $5.9\text{N}$ ( $0.6\text{Kgf}$ ) 以下	引抜力 $0.98\text{N}$ ( $100\text{gf}$ ) 以上	6. 13				
		10回目	" "	" $0.78\text{N}$ ( $80\text{gf}$ ) 以上					
		12極	初回	" $73.5\text{N}$ ( $7.5\text{Kgf}$ ) 以下		" $13.6\text{N}$ ( $2.0\text{Kgf}$ ) 以上			
			10回目	" "		" $14.7\text{N}$ ( $1.5\text{Kgf}$ ) 以上			
		10極	初回	" $68.6\text{N}$ ( $7.0\text{Kgf}$ ) 以下		" $19.6\text{N}$ ( $2.0\text{Kgf}$ ) 以上			
			10回目	" "		" $14.7\text{N}$ ( $1.5\text{Kgf}$ ) 以上			
		9極	初回	" "		" $19.6\text{N}$ ( $2.0\text{Kgf}$ ) 以上			
			10回目	" "		" $14.7\text{N}$ ( $1.5\text{Kgf}$ ) 以上			
		4. 2. 14	コネクタ挿抜力	8極		初回	" $63.7\text{N}$ ( $6.5\text{Kgf}$ ) 以下	" $14.7\text{N}$ ( $1.5\text{Kgf}$ ) 以上	6. 14
						10回目	" "	" $9.8\text{N}$ ( $1.0\text{Kgf}$ ) 以上	
7極	初回			" $53.9\text{N}$ ( $5.5\text{Kgf}$ ) 以下	" $14.7\text{N}$ ( $1.5\text{Kgf}$ ) 以上				
	10回目			" "	" $9.8\text{N}$ ( $1.0\text{Kgf}$ ) 以上				
6極	初回			" $49.0\text{N}$ ( $5.0\text{Kgf}$ ) 以下	" $14.7\text{N}$ ( $1.5\text{Kgf}$ ) 以上				
	10回目			" "	" $9.8\text{N}$ ( $1.0\text{Kgf}$ ) 以上				
5極	初回			" $39.2\text{N}$ ( $4.0\text{Kgf}$ ) 以下	" $14.7\text{N}$ ( $1.5\text{Kgf}$ ) 以上				
	10回目			" "	" $9.8\text{N}$ ( $1.0\text{Kgf}$ ) 以上				
4極	初回			" $29.4\text{N}$ ( $3.0\text{Kgf}$ ) 以下	" $9.8\text{N}$ ( $1.0\text{Kgf}$ ) 以上				
	10回目			" "	" $7.8\text{N}$ ( $0.8\text{Kgf}$ ) 以上				
3極	初回	" $24.5\text{N}$ ( $2.5\text{Kgf}$ ) 以下	" $7.8\text{N}$ ( $0.8\text{Kgf}$ ) 以上						
	10回目	" "	" $4.9\text{N}$ ( $0.5\text{Kgf}$ ) 以上						
2極	初回	" $19.6\text{N}$ ( $2.0\text{Kgf}$ ) 以下	" $7.8\text{N}$ ( $0.8\text{Kgf}$ ) 以上						
	10回目	" "	" $4.9\text{N}$ ( $0.5\text{Kgf}$ ) 以上						
4. 2. 15	パネル挿入力・保持力 (パネル取付盤のみに適用)	パネル挿入力	7, 8極	$78.4\text{N}$ ( $8\text{Kgf}$ ) 以下	6. 15				
			2~6極	$49.0\text{N}$ ( $5\text{Kgf}$ ) 以下					
		パネル保持力	7, 8極	$98.1\text{N}$ ( $10\text{Kgf}$ ) 以上					
			2~6極	$73.5\text{N}$ ( $7.5\text{Kgf}$ ) 以上					

## 5. 品質保証条件

## 5.1 試料

試料は完全に管理された製品を使用すること。

## 5.2 試験環境

下記に示す環境条件のもとで試験を行うこと。

温度	15℃～35℃
湿度	45%～75%
気圧(水銀柱)	$8.7 \times 10^4 \sim 1.07 \times 10^5 \text{ Pa}$ (650~800mmHg)

分類:

製品規格

標準の名称:

AMP E.I. シリーズ・コネクタ

標準のコード:

108-5118

改訂 3頁

J1 9頁中

図 1 電流対温度上昇特性

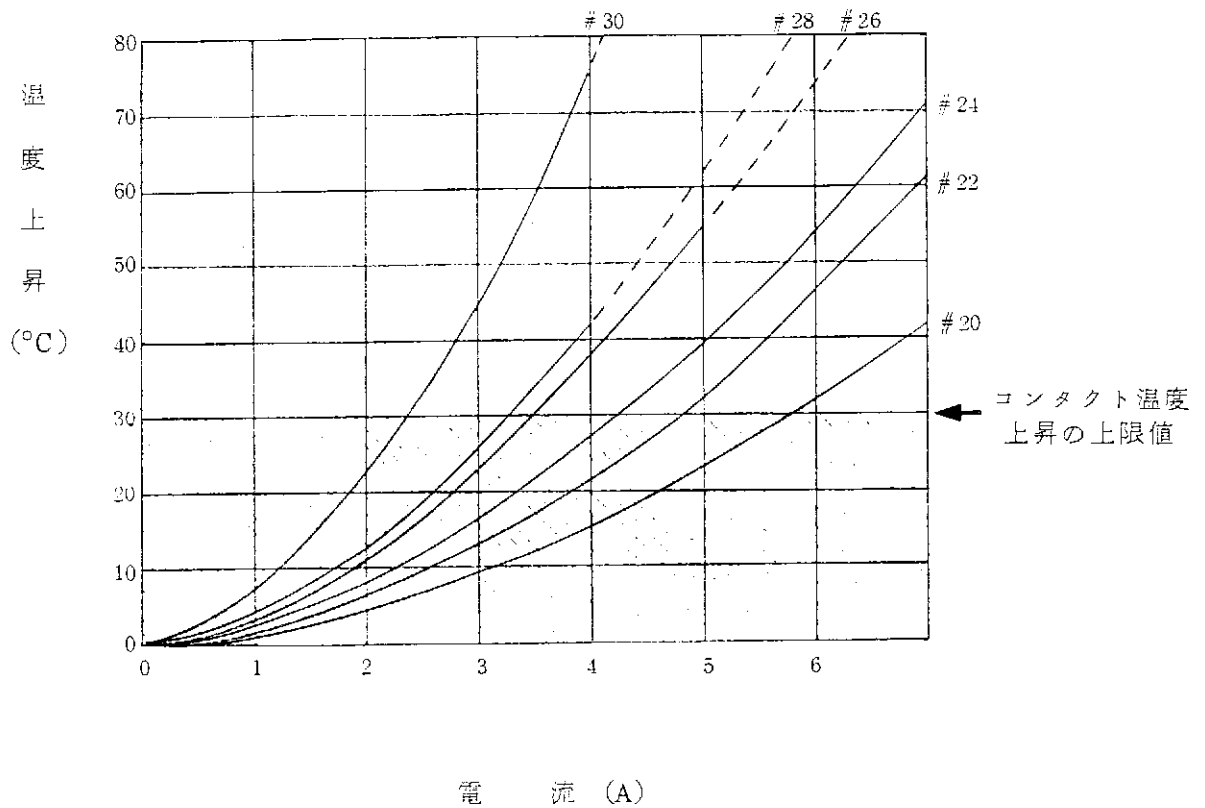

本製品の最大許容温度は、ハウジングの最大許容温度、錫メッキ・コンタクトの最大許容温度により、 $-20^{\circ}\text{C}$ ～ $+95^{\circ}\text{C}$ の範囲とし、使用電流によるコンタクト部分の温度上昇分と使用環境による周囲温度の和により次式から算出される。

$$\text{最大許容温度} = \text{温度上昇} + \text{周囲温度}$$

この時の温度上昇は、個々の電線の許容電流値以下とし、電線サイズと種類及び電流値により図1より選ぶこと。

但し、電流値は温度上昇が $30^{\circ}\text{C}$ 以下の範囲内とする。

## 6. 試験方法

## 6.1 ローレベル抵抗試験方法

図2に示す如く、回路電流 50 mA 以下、回路開放電圧 50 mV 以下の測定回路において測定し、電線導体抵抗 75 mm 分を差し引いて算出する。

## 6.2 絶縁抵抗試験方法

コネクタを嵌合状態（ポストヘッダーは基板に取付けないで）にし、ハウジング内の隣接している端子相互間を DC 500 V で測定する。

## 6.3 耐電圧試験方法

コネクタを嵌合状態（ポストヘッダーは基板に取付けないで）にし、ハウジング内の隣接している端子相互間に AC 750 V、1 分間印加する。

## 6.4 温度上昇試験方法

試料を直列になるように結線し、測定カ所はコンタクト圧着部分を熱電対法にて測定する。

## 6.5 コンタクト保持力試験方法

ハウジングをショッパー引張試験機に取り付け、ハウジングに挿着されたコンタクトを軸方向に毎分 100 mm の速度で操作して測定する。

## 6.6 低周波振動試験方法

嵌合状態の試料をプリント基板又は取付用パネルに固定し、直列回路になるように結線し、試験機に取り付け、0.1 A を通電して試験する。

振動方向は X, Y, Z 方向各 2 時間、最大全振幅 1.5 mm、振動周波数 10 ~ 55 Hz 往復 1 分間。（尚、電線対電線接続タイプはパネル取付型によって試験を代表する）

## 6.7 耐湿度試験方法

嵌合状態の試料を湿度 90 ~ 95 %、温度 40 °C の環境中で連続 96 時間放置後、室温中に 1 時間放置してから測定する。

## 6.8 塩水噴霧試験方法

嵌合状態の試料を、塩水濃度 5 %、温度 35 °C の環境中で連続 48 時間放置後、室温中に 1 時間放置してから測定する。

## 6.9 はんだ付試験方法（電線対器取タイプのポストヘッダーに適用）

ポスト・ヘッダーのはんだ付け部分をフラックス（アルファ 100, GX-5, GX-7）に 5 ~ 10 秒間浸漬した後 230 ± 5 °C のはんだ（錫 60 %, 鉛 40 %）槽中に 3 ± 0.5 秒間浸漬する。

分類：	標準の名称：	標準のコード：	改訂	5 頁
製品規格	AMP E.I. シリーズ・コネクタ	108-5118	J1	9 頁中



- 6.10 はんだ耐熱試験方法（電線対基板タイプのポストヘッダーに適用）  
 ポスト・ヘッダーをプリント基板の取付穴に挿入後  $260 \pm 5^\circ\text{C}$  のはんだ槽中に  $10 \pm 0.5$  秒間浸漬する。手半田の場合、ポスト・ヘッダーをプリント基板の取付穴に挿入後  $350 \pm 10^\circ\text{C}$  1~2秒にて半田付を行う。但しポストの半田付部にこて先等による加圧のなきこと。
- 6.11 圧着部引張試験方法  
 電線（撚線）を圧着したコンタクトをショッパー引張試験機に取り付け、軸方向に毎分  $100 \text{ mm}$  の速度で操作して測定する（被覆部は含まない）。
- 6.12 ポスト保持力試験方法（電線対基板タイプのポストヘッダーに適用）  
 ポスト・ヘッダー・アッセンブリーのハウジングを図3の如く治具で受け、ポスト先端を軸方向に垂直にフォース・ゲージで押して測定する。
- 6.13 コンタクト挿抜力試験方法  
 リセプタクル・コンタクトを引張試験機に取り付け、図4に規定するゲージを軸方向に毎分  $100 \text{ mm}$  の速度で操作し、測定する。
- 6.14 コネクタ挿抜力試験方法  
 コネクタを引張試験機に取り付け、軸方向に毎分  $100 \text{ mm}$  の速度で操作して嵌合、離脱を行いコネクタの挿入力及び引抜力を測定する。
- 6.15 パネル挿入力・保持力試験方法（電線対電線タイプパネル取付型キャップ  
 ハウジングに適用）  
 キャップハウジングを引張試験機に取り付け、軸方向に毎分  $100 \text{ mm}$  の速度で操作して製品図面上に指定された寸法で穴明けが施とされた取付用パネルへの挿入力および装着後の保持力を測定する。

## 7. 試験順序

試験は各試料をグループ別に分け、表2の順序で実施すること。

表 2

試験方法	試験項目	試験グループ番号											
		1	2	3	4	5	6	7	8	9	10	11	12
6.1	ローレベル抵抗			①③	①③	①③							
6.2	絶縁抵抗	①											
6.3	耐電圧	②											
6.4	温度上昇		①										
6.5	コンタクト保持力	③											
6.6	低周波振動			②									
6.7	耐湿性				②								
6.8	塩水噴霧					②							
6.9	はんだ付性						①						
6.10	はんだ耐熱性							①					
6.11	圧着部引張強度								①				
6.12	ポスト保持力									①			
6.13	コンタクト単体挿抜力										①		
6.14	コネクタ挿抜力											①	
6.15	パネル挿入力・保持力												①

分類：

製品規格

標準の名称：

AMP E.I. シリーズ・コネクタ

標準のコード：

108-5118

改訂

J1

7 頁

9 頁中

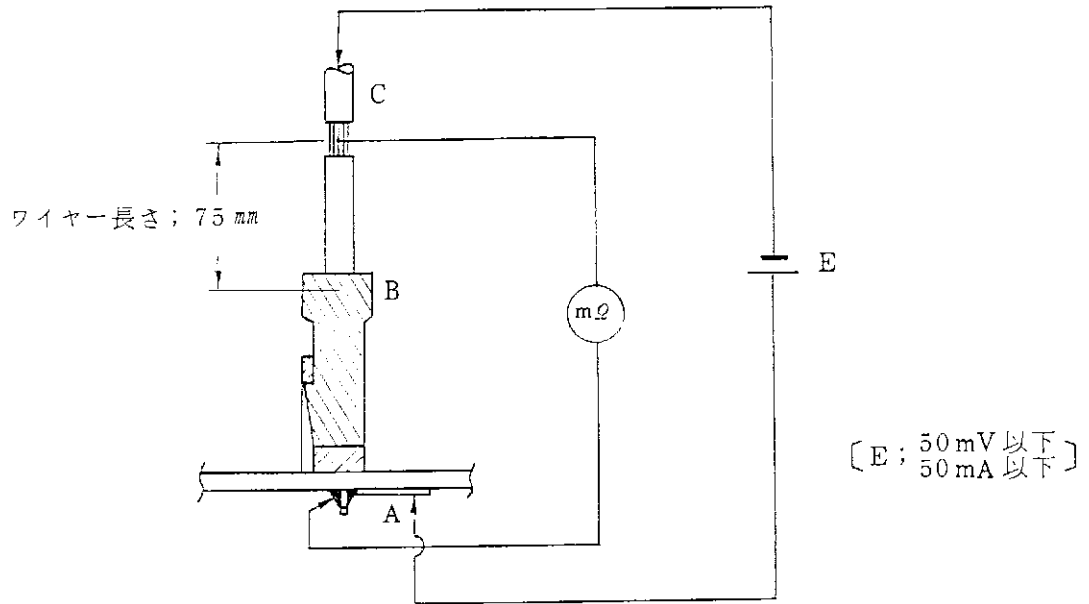

総合抵抗  $R = AB = AC - BC$  (mΩ)

電線対基板タイプ

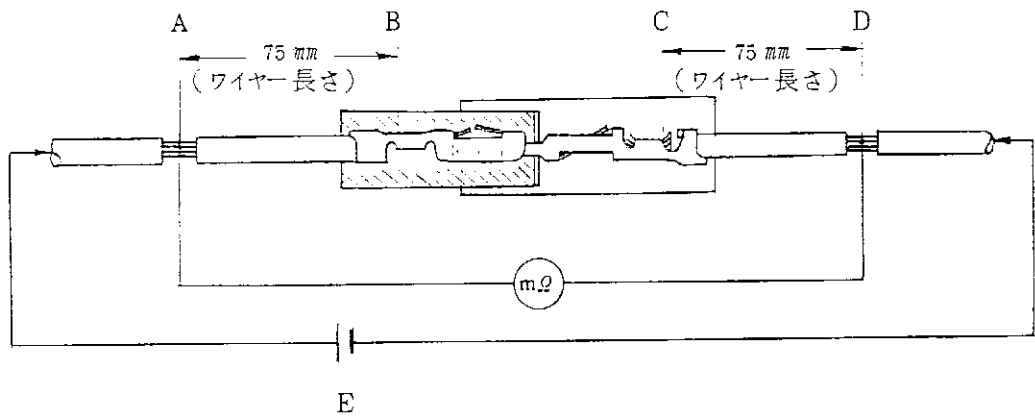

総合抵抗  $R = AD - (AB + CD)$  (mΩ)

電線対電線タイプ

図2 ローレベル抵抗試験方法

分類： 製品規格	標準の名称： AMP E.I. シリーズ・コネクタ	標準のコード： 108-5118	改訂 8 頁 J1 9 頁中
-------------	------------------------------	---------------------	-------------------

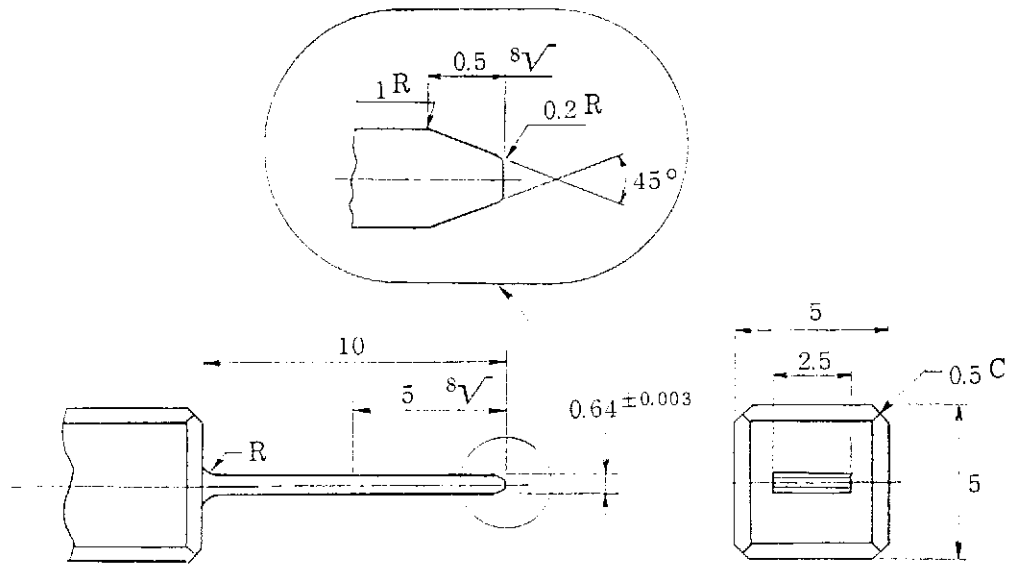

図 4 コンタクト挿抜力測定用ゲージ

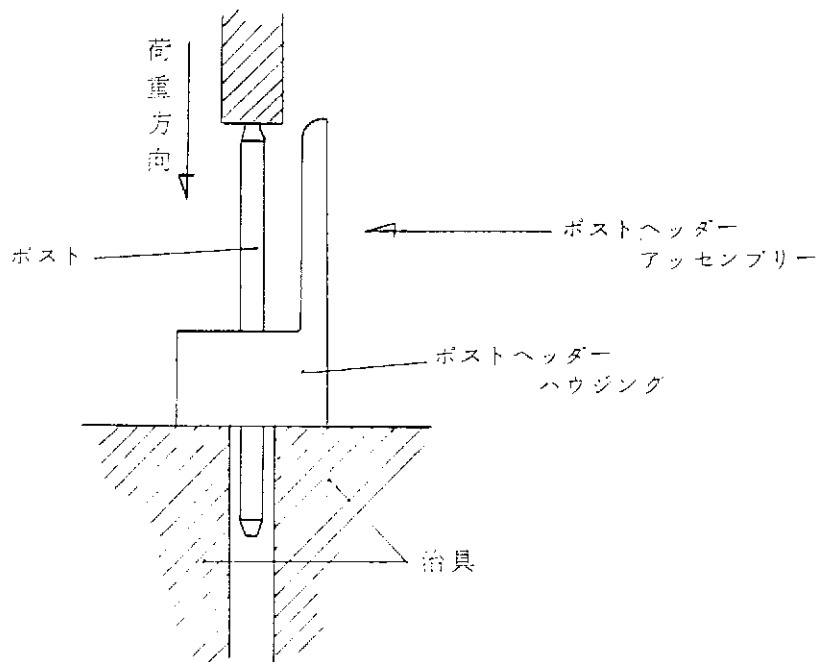

図 3 ポスト保持力試験方法

分類： 製品規格	標準の名称： AMP E.I. シリーズ・コネクタ	標準のコード： 108-5118	改訂 9 頁 J1 9 頁中
-------------	------------------------------	---------------------	-------------------